



Filters . Accumulators

High Pressure Filter

Manifold mounting
Type : 250/450-FE/FEN



Hydraulic Symbol

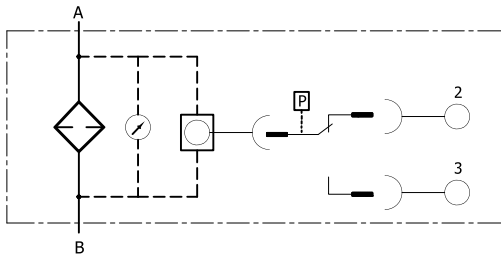

Technical Data

Material of Construction

- Head : GGG50
- Bowl : Carbon Steel.
- Seals : Nitrile / Viton / EPDM.
- Paint : Bowl Externally painted in RAL-5010.
Others on request.

- Design : Simplex Manifold mounting
- Max. Pressure (PS) : 250 / 450 Bar.
- Test Pressure (PT) : 1.43 x PS
- Temperature range : -20°C to +100°C (Standard)
- Connection : Upto DN50
- Element design : FE Series - EPE standard
FEN Series - As per DIN-24550

Description

The 250/450-FE/FEN series Filters are used for direct manifold mounting avoiding piping and provide wear protection of downstream components & systems. The filter inlet & outlet are on the same plane and located one above the other with inlet on the top. The flow path arrows (inlet and outlet) are marked on filter head.

The Filter head is provided with an element locating spigot. The Filter bowl is mounted below the filter head and is unscrewed for maintenance.

Accessories

Maintenance indicator - for monitoring the filter element contamination status. Available in various designs including

- Optical (pop-up version) with Electrical option.
- Optical (dual dial version) with Electrical option.
- Optical-Electrical with 2 switching points.

Magnet - to protect the filter from ferrous contamination.

Drain valve - for draining the filter during servicing.

Filter Element

The Filter Element is of star-pleated design with optimised pleat density for providing prolonged life.

The filter element is of Out-to-In design and the contaminant is retained outside the filter element and collected in the filter bowl.

The elements are available in various media options and selected based on the required oil cleanliness, initial pressure drop and dirt holding capabilities.

- Media options for the filter element include
- SS Wire Mesh - Cleanable, Nominal filtration.
- Paper - Non-cleanable, Nominal filtration.
- Non-woven - Non-cleanable, Nominal filtration.
- Inorganic glass fibre - Non-cleanable, Absolute filtration acc. to ISO-16889.
- Aquasorb - Water absorbing media, Non-cleanable.

For special applications / fluids the filter elements are supplied with SS hardware (end caps & inner tube) and / or different adhesives.

Technical specifications subject to change.

Ordering Code - Filter

1 2 3 4 5 6ab 7 8 9ab 10 11 12 13
450 - **FE** - **0013** - **H10XL** - **A** - **00** - **0** - **0** - **A5.0** - **00** - **P** - **0** - **0** /

1	Max. working pressure	250 Bar 450 Bar	= 250 = 450
2	Filter type	Manifold mounting - EPE Standard Element Manifold mount - Element acc. to DIN 24550	= FE = FEN
3	Nominal Size	Filter type FE Filter type FEN	= 0003 (* 2.0004 element) 0005 0008 0013 0015 0018 0020 0030 0045 0095 0145 = 0040 0063 0100 0160 0250 0400 0630 1000
4	Filtering Media & Filtration Grade	<u>Nominal Filtration Grade in µm</u> SS Wire Mesh Cleanable Paper Non-cleanable Non-Woven Non-cleanable <u>Absolute Filtration Grade (ISO16889) in µm</u> Glass Fibre with epoxy wire mesh support Non-cleanable Glass Fibre with plastic mesh support Non-cleanable Water Absorbing Glass Fibre Non-cleanable	= G10 G25 G40 G60 G80 G100 Others on request = P5 P10 P25 = VS10 VS25 VS40 VS60 = H1XL H3XL H5XL H6XL H10XL H16XL H20XL = H1XP H3XP H5XP H6XP H10XP H16XP H20XP = AS1 AS3 AS6 AS10 AS20
5	Differential Pressure of Element	<u>Maximum allowed differential pressure</u> 30 Bar 60 Bar 160 Bar 330 Bar	= A (standard) = D = C = B
6a	Element Adhesive	Standard Adhesive T=100°C Epoxy Adhesive (for fuels) High Temp. Adhesive T=160°C	= 0 (standard) = 1 = E
6b	Element Hardware	Standard (Carbon Steel / Polyamide) All Stainless Steel (30 Bar DP)	= 0 (standard) = V
7	Magnet	Without With ring magnet ^(a)	= 0 (standard) = X
8	Bypass Valve	Without With Bypass valve (on request)	= 0 (standard) = *

* Before ordering, check for availability.

^(a) Magnets kept loose under the elements.

Ordering Code - Filter

1 2 3 4 5 6ab 7 8 9ab 10 11 12 13
450 - FE - 0013 - H10XL - A - 00 - 0 - 0 - A5.0 - 00 - P - 0 - 0 /

9a	Maintenance Indicator - type	Without Optical (Pop-up) Optical(Pop-up) + Electrical with DIN Plug Optical(Pop-up) + Electrical with Lamp Optical + Electrical with 2 Switching points - set to operate at 75% and 100% Optical (Dual dial) Optical(dial) + Electrical with DIN Plug Optical(dial) + Electrical with Lamp Special	= 0 (standard) = A.. = B.. = D.. = T.. = AD.. = BD.. = DD.. = SP
9b	Maintenance Indicator - cracking pressure	Without 0.8 Bar 1.5 Bar 2.5 Bar 4.2 Bar 5.0 Bar 6.0 Bar 7.0 Bar Other pressure (in Bar)	= - (standard) = ..0.8 = ..1.5 = ..2.5 = ..4.2 = ..5.0 (standard) = ..6.0 = ..7.0 = as applicable
10	Inlet / Outlet - connections (Refer C1 on pg.5)	Catalogue Connections	= 00 (DN14 DN18 DN32 DN50)
11	Seal Material	Nitrile Viton	= P = V
12	Housing Material	Standard - as per catalogue Special	= 0 = SP
13	Other Options (multiple options possible)	Without With 1/4" drain port - duly plugged With 1/4" CS drain valve in bowl With 1/4" SS drain valve in bowl Filter Element with Outer Sleeve	= 0 = 4 = DV = DVX = X

* Before ordering, check for availability

Ordering Code - Filter Element

3 4 5 6ab 8 11
2. 0013 - H10XL - A - 00 - 0 - P

Ordering Code - Filter Seal Kit

1 2 3 9a 10 11 12
D - 450 - FE - 0013 - A - 00 - P - 0

Maintenance Indicators

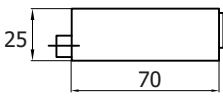
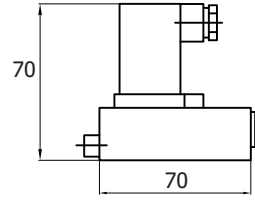
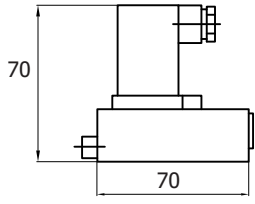
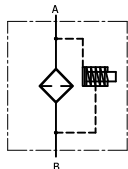
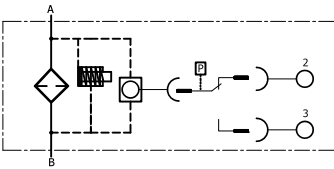
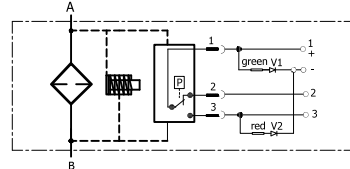
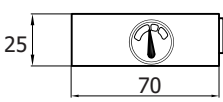
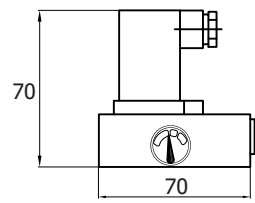
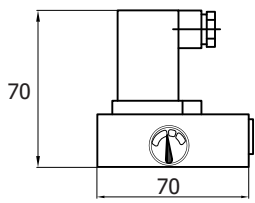
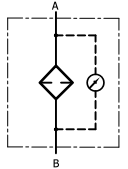
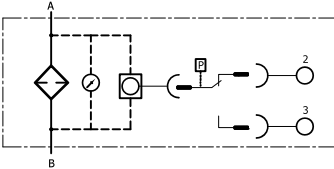
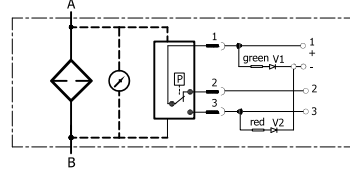
		
A = Optical (Pop-up)	B = Optical (Pop-up) + Electrical	D = Optical (Pop-up) + Electrical with 2 LEDs
Ordering Code F-xx-A0-00-00-P	Ordering Code F-xx-GW-02-00-P	Ordering Code F-xx-GW-26-00-P
		
		
AD = Optical (Dual Dial)	BD = Optical (Dual Dial) + Electrical	DD = Optical (Dual Dial) + Electrical with 2 LEDs
Ordering Code FD-xx-A0-00-00-P	Ordering Code FD-xx-GW-02-00-P	Ordering Code FD-xx-GW-26-00-P
		

Maintenance Indicator functioning

These indicators work on the differential pressure and operate when a preset pressure differential is reached between the inlet & outlet ports. In the pop-up version a red indicator pin pops out in the housing chamber thereby indicating the state whereas in the dual dial version two dial gauges - with green, yellow & red bands - placed on opposite side indicate the condition. If available, the electronic switching element is also triggered.

In the 2-switching points version (type T) the green LED glows in operating condition, yellow LED glows when 75% of the preset pressure differential is reached and red LED at 100%.

Tightening Torque Values (Nm ±10%)

Type	Inlet/Outlet Port Size	Bowl to head Torque	Mounting Hole Size	Mounting Bolt
250/450 FE 0003-0013	Ø14	40	Ø14	M12
250/450 FE 0015-0018	Ø18	50	Ø18	M16
250/450 FE 0020-0045	Ø32	60	Ø23	M20
450 FE 0095-0145	Ø50	60	Ø27	M24
250/250 FEN 0040-0100	Ø14	40	Ø14	M12
250/450 FEN 0160-0400	Ø32	60	Ø23	M20
450 FEN 0630-1000	Ø50	60	Ø27	M24

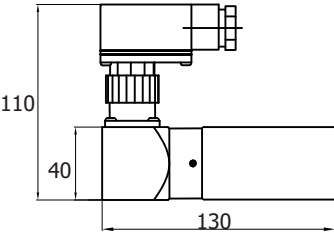

T = Optical/Electrical with 3 LEDs & 2 Switching points

Ordering Code
R-xx-GW-09-Z0-P

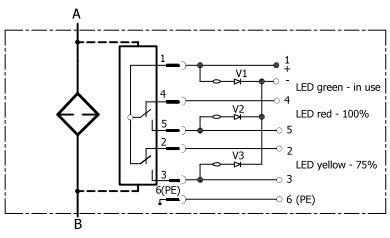

xx - preset differential pressure (bar)

Dimensions

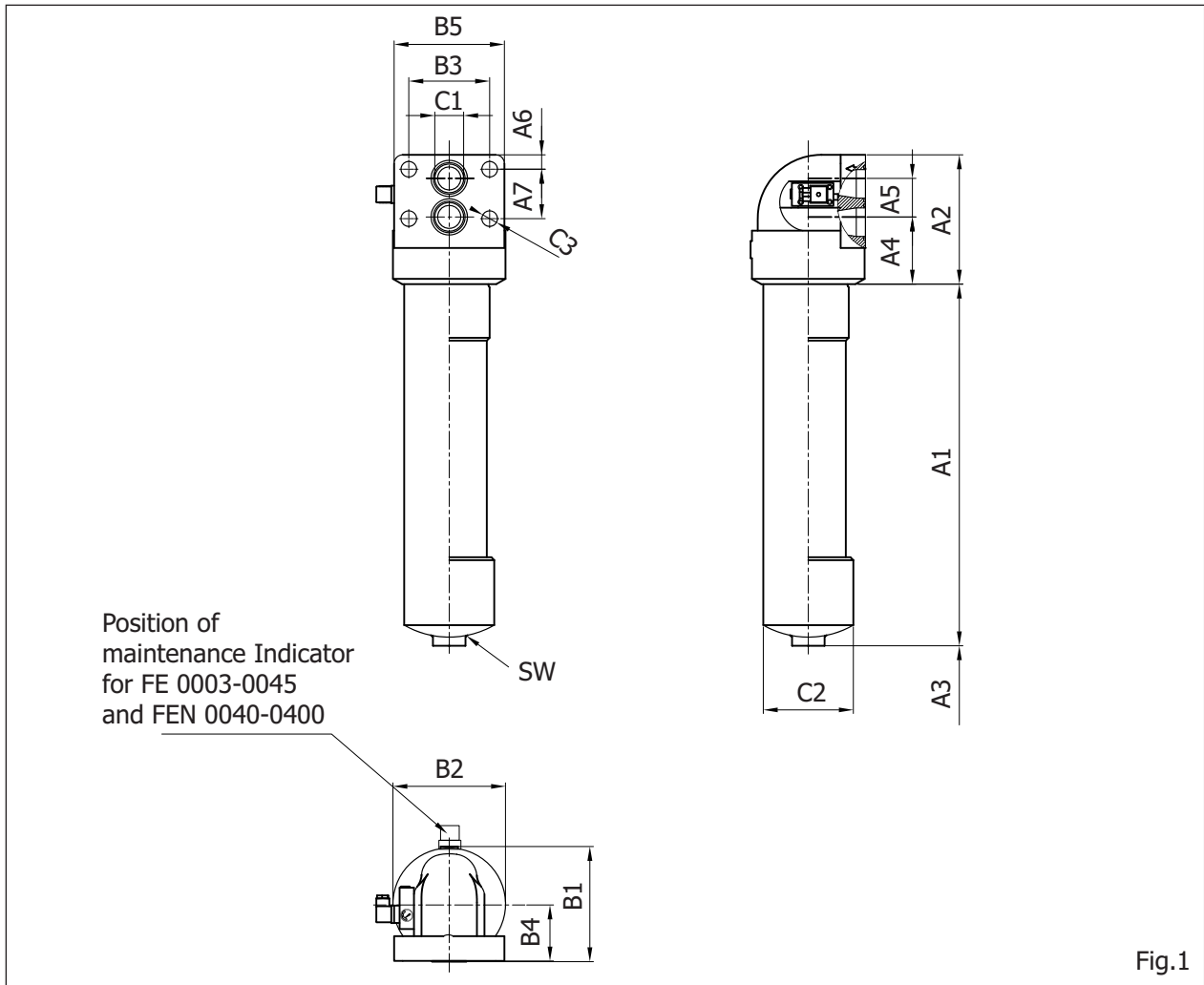

Filter housing for Filter Elements in accordance with EPE standard

Type	Capacity in ltr	Weight in kg ¹⁾	A1	A2	A3 ²⁾	A4	A5	A6	A7	B1	B2	B3	B4	B5	C1	C2	C3	SW
250/450 FE 0003	0.2	4.6	98	112	100	56	28	12	45	95	88	57	48	80	Ø14	Ø67	Ø14	24
250/450 FE 0005	0.2	4.6	98		110													
250/450 FE 0008	0.3	5.9	161		110													
250/450 FE 0013	0.5	6.1	251		110													
250/450 FE 0015	0.9	11.0	188	150	130	80	35	20	55	130	125	72	65	110	Ø18	Ø92	Ø18	32
250/450 FE 0018	1.1	12.7	239															
250/450 FE 0020	1.3	16.8	167															
250/450 FE 0030	1.9	19.2	257															
250/450 FE 0045	3.0	24.1	407	160	150	79.5	52	22.5	60	156	150	95	80	140	Ø32	Ø114	Ø23	32
450 FE 0095	4.5	47.5	421															
450 FE 0145	6.2	67.5	641															
				225		117	67	25	86	199	195	140	99	190	Ø50	Ø140 Ø156	Ø27	41

Filter housing for Filter Elements in accordance with DIN 24550

Type	Capacity in ltr	Weight in kg ¹⁾	A1	A2	A3 ²⁾	A4	A5	A6	A7	B1	B2	B3	B4	B5	C1	C2	C3	SW
250/450 FEN 0040	0.2	4.6	98	112	110	56	28	12	45	95	88	57	48	80	Ø14	Ø67	Ø14	24
250/450 FEN 0063	0.3	5.9	161															
250/450 FEN 0100	0.5	6.1	251															
250/450 FEN 0160	1.3	16.8	167															
250/450 FEN 0250	1.9	19.2	257	160	150	79.5	52	22.5	60	156	150	95	80	140	Ø32	Ø114	Ø23	32
250/450 FEN 0400	3.0	24.1	407															
450 FEN 0630	4.5	47.5	421															
450 FEN 1000	6.2	67.5	641	225		117	67	25	86	199	195	140	99	190	Ø50	Ø140 Ø156	Ø27	41

¹⁾ = Weight including standard filter element and maintenance indicator

²⁾ = Servicing height for filter element replacement

Spare parts list

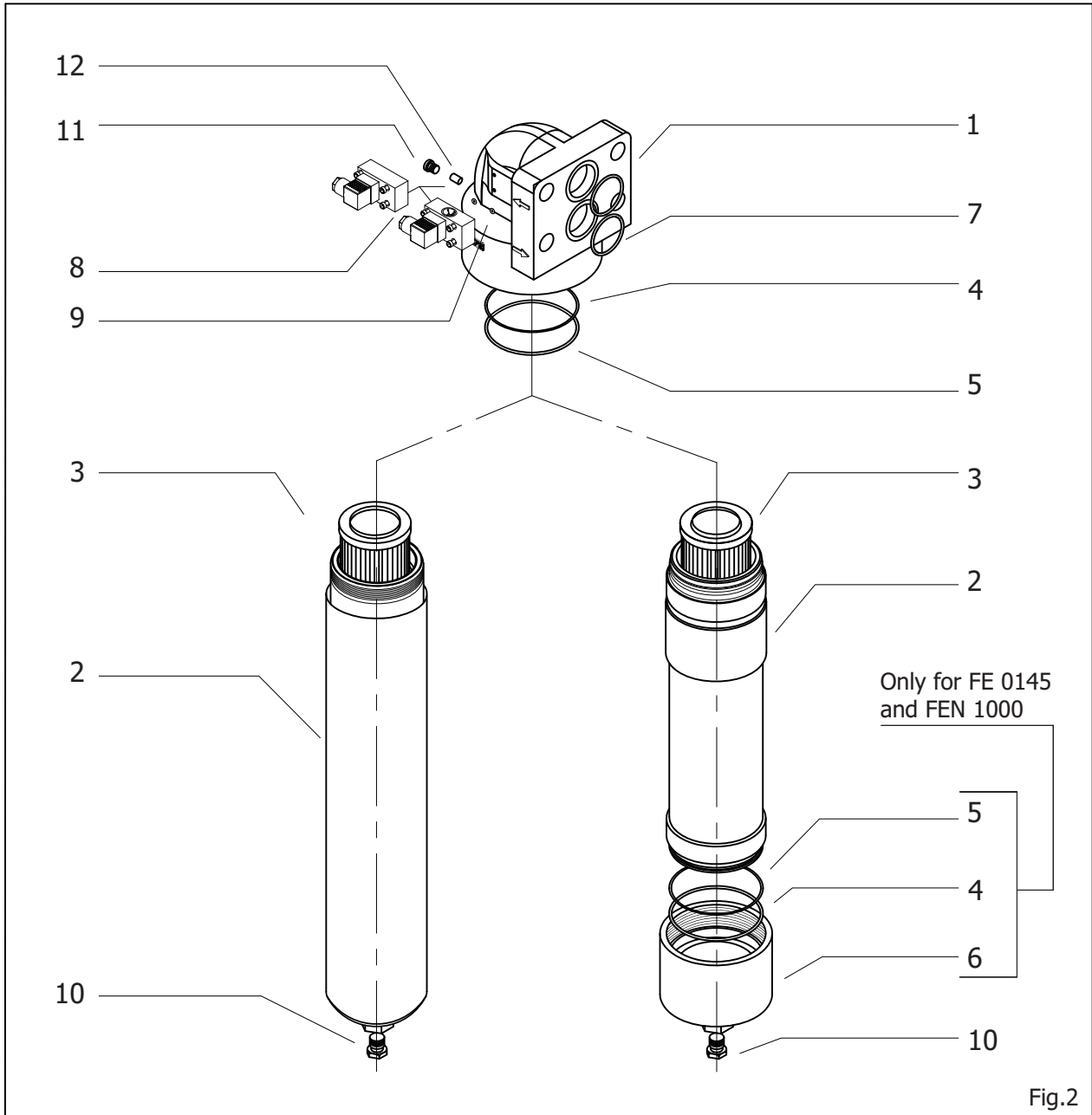

Fig.2

Spare Parts List

		Size FE Size FEN		0003	0005 0040	0008 0063	0013 0100	0015	0018	0020 0160	0030 0250	0045 0400	0095 0630	0145 1000
Item #	Qty.	Description	Material											
1	1	Filter Head	GGG50						-					
2	1	Filter Bowl	Carbon steel						-					
3	1	Filter Element	Various	As per "Ordering Code - Filter Element"										
4	1(2)	Housing O-Ring	Buna N/Viton	Sold as kit - "Ordering Code - Filter Seal Kit"										
5	1(2)	Support Ring	Teflon	Sold as kit - "Ordering Code - Filter Seal Kit"										
6	1	Bottom Bowl	Carbon Steel						n/a					-
7	2	Head O-Rings	Buna N/Viton	Sold as kit - "Ordering Code - Filter Seal Kit"										
8	1	Indicator	Carbon Steel	As per Section "Maintenance Indicator"										
9	2	Indicator O-Rings	Buna N/Viton	Sold as kit - "Ordering Code - Filter Seal Kit"										
10	1	Drain plug	Steel	Part No.DBP01										
11	1	Plug	Steel						n/a					-
12	1	Set Screw	5.8						n/a					-

Installation

Before installation, conduct a visual check to ensure that the filter has not suffered any damage during shipping / handling. Verify that the requested type matches with what stamped on the nameplate.

Verify operating pressure with name plate information.

During assembly of the filter the flow direction (direction arrows on the filter head) and the required service height (A3 in fig.1) of the filter element are to be taken into consideration.

Mount the filter assembly using the mounting holes on the filter head (C3) considering the flow direction. Failure to observe flow direction during assembly with cause damage to the filter element and components downstream.

Tighten the mounting bolts adequately.

We recommend using a suitable safety relief valve in the system to ensure the user and equipment are protected against possible damage caused by pressure surges.

Provide for the required servicing clearance below the filter for cleaning / replacing the filter element.

These filters must preferably be installed in vertical position with the filter bowl at the bottom to ensure proper venting and draining.

Proceed to the assembly ensuring the filter is not subjected to any abnormal forces and also fastened to avoid the transmission of vibrations. Tighten the inlet and outlet connections to the specified torques.

Make sure the optical part of the indicator is visible and the electricals connected appropriately.

If the maintenance indicator is ignored the element can collapse thereby bypassing the filter element and contaminated fluid will pass to the clean side of the filter outlet thereby compromising the filtration effectiveness and risking the downstream components.

Connecting electrical indicator

Connect indicator using the three wired cable.

Verify electrical ratings on the indicator (6) name plate.

Connection settings:

- | | |
|------------|----------------------------------|
| 1. Closer | 1 (black) + 3 (blue) |
| 2. Opener | 1 (black) + 2 (brown) |
| 3. Changer | 1 (black) + 2 (brown) + 3 (blue) |

Special Instructions

It is strictly forbidden to:

- weld or solder or carry out any mechanical operations on the filter.
- engrave or permanently stamp the surfaces of the filter and / or carry out other operations that could affect or change the mechanical properties of the filter.
- use the filter as a structural element: it should not be subjected to stresses or loads.
- change the data of the nameplate and / or filter without the permission of the manufacturer.
- use a different fluid than those designed for.

Starting Operation

Switch on the service pump.

Ensure the filter is completely filled with the working fluid and air in the housing vented.

Maintenance

The filter element is clogged and must be changed or cleaned when at operating temperature the red pointer on the pop-up indicator (8) is hard against the plastic cap / the pointer on the dual dial indicator (8) is at the end of the red marking and / or the switching process on the electrical indicator is triggered.

Filter element service

Switch off pump. Drain the filter housing through the drain plug (10) / drain valve. Unscrew filter bowl (2) and remove filter element (3), turning slightly off from its locator in the filter head (1). Check filter bowl inside and clean if necessary.

Filter element of type H...-XL,, H...-XP, AS..., P... and VS ... is to be replaced.

Filter element with G... media is cleanable. The effectiveness of cleaning depends on the type of dirt and the level of the differential pressure at the time of changing the filter element. If the differential pressure after the filter element's cleaning process exceeds more than 50% of the pre-service value the G...filter element also needs to be replaced.

Remove the safety packing from the new filter element before installing in the filter.

Replace filter element by slightly turning it back on its locator. Check Housing O-Ring (4) and Support Ring (5) on filter bowl (2), replace in case of damage or wear. Screw filter bowl and tighten to the specified torque (page 4) at hexagon bolt using a suitable tool.

Operate filter as described above.

Pressure Directives

Pressure Line Filters for hydraulic application are pressure holding equipment according to Article 2 Section 5 of the Pressure Equipment Directive 2014/68/EU. However, on the basis of the exception in Article 1, Section 2(f) of the PED the pressure line filters are exempt from the PED if they are not classified higher than category I (Guideline A-19) & do not receive any CE mark.

Disposal / Environmental Protection

Careless disposal of the filter, filter element and the residual fluid contained therein can cause environmental pollution.

Dispose the filter / filter element in accordance with provisions applicable in the country of use.

Fluid residues are to be disposed according to the respective safety data sheets valid for the specific hydraulic fluids.

Performance Curves (Flow rate Vs Pressure Drop) - for complete filters

Oil Viscosity : 30 mm²/s
 Specific gravity < 0.9 kg/dm³
 Recommended initial Pressure Drop (ΔP) for assembly = 1.5 bar.

