



Filters . Accumulators

Returnline Inline Filter

Tank top / Line mounting
Type : 16-FR/L / FR/LN

Technical Data

Design	: Simplex Tanktop / line mounting
Max. Pressure (PS)	: 16 bar [232 psi]
Test Pressure (PT)	: 1.43 x PS (as per CE/PED) 1.3 x PS (as per ASME)
Temperature range	: -20°C to +100°C (Standard) -4°F to +212°F (Standard)
Connection	: Upto SAE 4" / SAE-64
Element design	: FR/L Series - EPE standard FR/LN Series - As per DIN-24550

Material of Construction

Cover	: Aluminium Alloy.
Housing	: Aluminium Alloy.
Seals	: Nitrile/Viton/EPDM/Neoprene/Butyl.

Flow Capacity

0020 / 0160	200 lpm [50 gpm]
0030 / 0250	300 lpm [65 gpm]
0045	450 lpm [100 gpm]
0060 / 0400	600 lpm [150 gpm]
0095 / 0630	950 lpm [250 gpm]
0120	1200 lpm [300 gpm]
0145 / 1000	1450 lpm [380 gpm]
0200	2000 lpm [525 gpm]
0270	2700 lpm [700 gpm]



Hydraulic Symbol

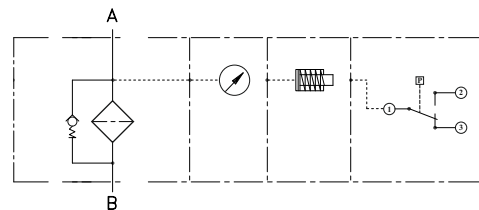

Description

The FR/L & FR/LN series Filters are used for tank top mounting in the return line of the system and provide protection for tank and operating pumps as a result of filtering out dirt from the installation runback. The inlet is on top part of the housing which is outside the tank while the outlet is at the bottom of the housing and discharges into the tank.

These filters can also be used as low pressure line filters.

The filter housing has an element locating spigot. The top cover is used for holding the element and is unscrewed for maintenance.

Accessories

Maintenance indicator - for monitoring the filter element contamination status. Available in various designs including

- Optical (pop-up version & gauge version).
- Electrical - NO, NC & switch-over.
- Optical-Electrical.

Bypass valve - to protect the filter element during start-up and over pressurisation due to clogging.

Filter Element

The Filter Element is of star-pleated design with optimised pleat density for providing prolonged life.

The filter element is of Out-to-In design and the contaminant is retained outside the filter element and collected in the filter bowl.

The elements are available in various media options and selected based on the required oil cleanliness, initial pressure drop and dirt holding capabilities.

Media options for the filter element include

- SS Wire Mesh - Cleanable, Nominal filtration.
- Paper - Non-cleanable, Nominal filtration.
- Non-woven - Non-cleanable, Nominal filtration.
- Inorganic glass fibre - Non-cleanable, Absolute filtration acc. to ISO-16889.
- Aquasorb - Water absorbing media, Non-cleanable.

For special applications / fluids the filter elements are supplied with SS hardware (end caps & inner tube) and / or different adhesives.

Technical specifications subject to change.

Ordering Code - Filter

1 2 3 4 5 6ab 7 8 9ab 10 11 12 13
16 - **FR/L** - **0045** - **H10XP** - **A** - **0 P** - **0** - **7** - **D2.5** - **G08** - **P** - **0** - **0** /

1	Max. working pressure	16 bar [232 psi]	= 16
2	Filter type	Return & Inline - EPE Standard Element Return & Inline - Element acc. to DIN 24550	= FR/L = FR/LN
3	Nominal Size	Filter type FR/L Filter type FR/LN	= 0020 0030 0045 0060 0095 0120 0145 0200 0270 = 0160 0250 0400 0630 1000
4	Filtering Media & Filtration Grade	<u>Nominal Filtration Grade</u> SS Wire Mesh Cleanable with additional epoxy layer upstream for 10/25/40µm	= G10 G25 G40 G60 G80 G100 Others on request
		Paper Non-cleanable with epoxy mesh	= P5 P10 P25
		Non-Woven Non-cleanable with epoxy mesh	= VS10 VS25 VS40 VS60
		<u>Absolute Filtration Grade (ISO16889)</u> Glass Fibre Non-cleanable with epoxy mesh	= H1XL H3XL H6XL H10XL H16XL H20XL
		Long Life Glass Fibre Non-cleanable with plastic mesh & outer sleeve	= H3XP H5XP H10XP H15XP H20XP
		Long Life Glass Fibre Non-cleanable with epoxy mesh	= H3XE H5XE H10XE H15XE H20XE
		Glass Fibre - Electrically Conductive Non-cleanable with epoxy mesh	= H3XC H5XC H10XC H15XC H20XC
		Glass Fibre - Water Absorbing Non-cleanable with epoxy mesh	= AS1 AS3 AS6 AS10 AS20
	SS Fibre Cleanable with SS mesh	= M5 M10 M15	
5	Differential Pressure of Element	<u>Maximum allowed differential pressure</u> 30 Bar [435 psid] 15 Bar [217 psid]	= A (0020-0120) = 0 (0145-0270)
6a	Element Adhesive	Standard Adhesive T=100°C [212°F] Epoxy Adhesive (for fuels) High Temp. Adhesive T=160°C [320°F]	= 0 (standard) = 1 = E
6b	Element Hardware (End Caps + Inner Tube)	Carbon Steel + Carbon Steel Polyamide + Carbon Steel Stainless Steel + Stainless Steel Nickel Coated CS + Nickel Coated CS	= C = P (standard) = X = D
7	Magnet	Without	= 0 (standard)

* Before ordering, check for availability.

Ordering Code - Filter

1 2 3 4 5 6ab 7 8 9ab 10 11 12 13
16 - FR/L - 0045 - H10XP - A - 0 P - 0 - 7 - D2.5 - G08 - P - 0 - 0 /

8	Bypass Valve #	Without bypass valve With Bypass Valve - 3.5 Bar [50.7 psid] Others - on request	= 0 = 7 (standard)
9a	Maintenance Indicator - type	Without Optical-Manometer:0-6 kg/cm ² [0-85 psi] Optical-Manometer:0-25 kg/cm ² [0-350 psi] Optical - Pop-up Electrical - Pressure Switch - Closer - NO Electrical - Pressure Switch - Opener - NC Electrical - Pressure Switch - Switch-over Optical+Electrical - Switch-over+lamp Special	= 0 (standard) = A = B = C.. = D.. = F.. = G.. = K.. = SP
9b	Maintenance Indicator - cracking pressure	N/A 2.5 Bar [36.2 psid] Other pressure (in Bar)	= - (standard) = ..2.5 (std for C,D,F,G,K) = as applicable
10	Inlet connection (Refer C1 on pg.5)	BSP Thread (ISO-228) - 1-1/4" BSP(F) BSP Thread (ISO-228) - 1-1/2" BSP(F) SAE #3000 Flange - 1-1/4" SAE #3000 Flange - 1-1/2" SAE #3000 Flange - 2" SAE #3000 Flange - 2-1/2" SAE #3000 Flange - 3" SAE #3000 Flange - 4" SAE Straight Thread O'Ring Boss (J1926) With adaptor	= G07 = G08 = S073 = S083 = S093 = S103 = S113 = S133 = Syy (refer pg.5) = RA0 (to be specified)
11	Seal Material	Nitrile Viton EPDM Neoprene Butyl	= P (standard) = V = E = N = B
12	Housing Material	Standard - as per catalogue Special	= 0 (standard) = SP
13	Other Options (multiple options possible)	Without With 1/4" air vent port - duly plugged With 1/4" BSP Air Vent Valve Element with Handle	= 0 (standard) = EP = E = H

* Before ordering, check for availability

Bypass Valve assembled in the top cover

Ordering Code - Filter Element

Ordering Code - Seal Kit

1. **0045 - H10XP - A - 0 P - 0 - P**
 3 4 5 6ab 11

D - 16 - FR/L - 0045 - D - G08 - P - 0
 1 2 3 9a 10 11

Maintenance Indicators

<p>A = Optical (Manometer) 0-6 kg/cm²</p>	<p>B = Optical (Manometer) 0-25 kg/cm²</p>	<p>C = Optical (Pop-up)</p>
<p>Ordering Code A = M010</p>	<p>Ordering Code B = M040</p>	<p>Ordering Code C = Pxx</p>
<p>D = Normally Open - NO Electrical Closer/Maker</p>	<p>F = Normally Closed - NC Electrical Opener/Breaker</p>	<p>G = Electrical - Switch-over</p>
<p>Ordering Code D = Hxx-HA-32-00-P</p>	<p>Ordering Code F = Hxx-HS-32-00-P</p>	<p>Ordering Code G = Hxx-GW-33-00-P</p>

Maintenance Indicator functioning

Pressure indicators are used in the return line filters to ascertain the condition of the filter. These measure the pressure upstream of the filter element & operate when a preset pressure is reached.

The needle of the manometer indicates the pressure. In the pop-up version a red indicator pin pops out in the housing chamber thereby indicating the state.

The Electrical Indicators are triggered when the set pressure is reached and activate by opening /closing the circuit as designed. The Optical-Electrical version (type K) has additional green & red LEDs to indicate the state.

Tightening Torque Values : Nm [ft/lbs] ±10%

Type	Inlet Port - BSP		Top Cover Bolts		Mounting Holes	
	Size	Torque	Size	Torque	Size	Torque
16 FR/L 0020-0045 16 FR/LN 0160-0250	G 1-1/4"	80 [59]	M12	20 [15]	M10	15 [11]
16 FR/L 0060-0297 16 FR/LN 0400-1000	-	-	M10	15 [11]	M10	15 [11]

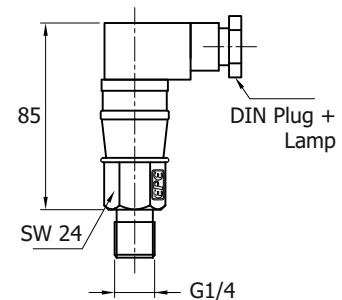

K = Electrical Switch-over + Lamp

Ordering Code
K = Hxx-GS-34-00-P

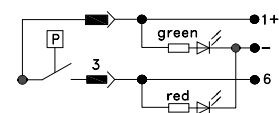

xx - preset differential pressure (bar)

Dimensions

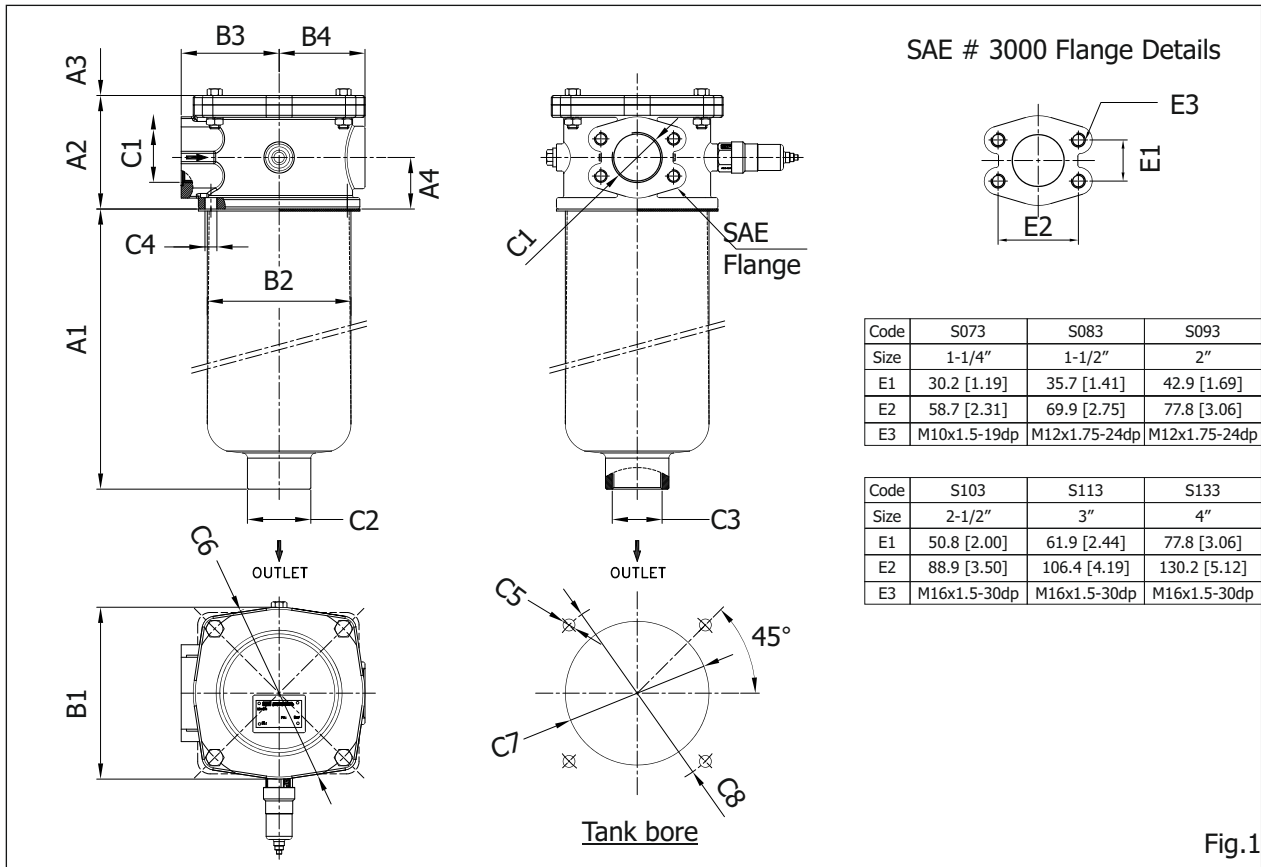

Fig.1

Type	Capacity ltr [gal]	Weight kg [lbs] ¹⁾	A1	A2	A3 ²⁾	A4	B1	B2 Tapered	B3	B4
16 FR/L 0020	3.3	6.22	179		160					
16 FR/LN 0160	[0.87]	[13.71]	[7.05]		[6.30]					
16 FR/L 0030	4.3	6.86	269		250	49.5	165	Ø138	94	82.5
16 FR/LN 0250	[1.14]	[15.12]	[10.59]	109	[9.84]	[1.95]	[6.49]	[5.43]	[3.70]	[3.25]
16 FR/L 0045	6.1	7.60	419		400					
16 FR/L 0060	6.6	8.30	238		250					
16 FR/LN 0400	[1.74]	[18.30]	[9.37]		[9.84]					
16 FR/L 0095	9.5	10.53	389		400	61	198	Ø175	110	99
16 FR/LN 0630	[2.51]	[23.21]	[15.31]	135	[15.75]	[2.40]	[7.79]	[6.89]	[4.33]	[3.90]
16 FR/L 0120	16.3	21.25	755		757					
16 FR/L 0145	15.0	18.60	397		400					
16 FR/LN 1000	[3.96]	[41.01]	[15.63]		[15.75]					
16 FR/L 0200	25.2	25.80	755	178	758	81	230	Ø193	135	115
	[6.66]	[56.88]	[29.72]	[7.01]	[29.84]	[3.19]	[9.05]	[7.60]	[5.32]	[4.53]
16 FR/L 0270	31.6	29.45	1154		992					
	[8.35]	[64.93]	[45.43]		[39.06]					

Type	Connections							
	Inlet - C1	Spout OD - C2	Outlet - C3	C4	C5	C6 PCD	C7 Tank Bore	C8 PCD
16 FR/L 0020	G07 : G1-1/4" (C1)	Ø60.8 [Ø2.39] (C2)	G1-1/2" (C3)					
16 FR/LN 0160	G08 : G1-1/2" (C1)	Ø60.8 [Ø2.39] (C2)	G1-1/2" (C3)					
16 FR/L 0030	S073 : SAE 1-1/4" (C1)	Ø60.8 [Ø2.39] (C2)	G1-1/2" (C3)	Ø11.5	M10	Ø165	Ø140	Ø185
16 FR/LN 0250	S083 : SAE 1-1/2" (C1)	Ø60.8 [Ø2.39] (C2)	G1-1/2" (C3)	[Ø0.45]		[Ø6.49]	[Ø5.51]	[Ø7.28]
16 FR/L 0045	S16 : 1-5/16-12 UN-2B (C1)	Ø60.8 [Ø2.39] (C2)	G1-1/2" (C3)					
	S20 : 1-5/8-12 UN-2B (C1)	Ø60.8 [Ø2.39] (C2)	G1-1/2" (C3)					
	S24 : 1-7/8-12 UN-2B (C1)	Ø60.8 [Ø2.39] (C2)	G1-1/2" (C3)					
16 FR/L 0060								
16 FR/LN 0400	S093 : SAE 2" (C1)	Ø69 [Ø2.72] (C2)	G2" (C3)	Ø11.5	M10	Ø210	Ø178	Ø220
16 FR/L 0095				[Ø0.45]		[Ø8.27]	[Ø7.01]	[Ø8.66]
16 FR/LN 0630								
16 FR/L 0120								
16 FR/L 0145								
16 FR/LN 1000	S103 : SAE 2-1/2" (C1)	Ø95 [Ø3.74] (C2)	G2-1/2" (C3)					
16 FR/L 0200	S113 : SAE 3" (C1)	Ø110 [Ø4.33] (C2)	G3" (C3)					
	S133 : SAE 4" (C1)	Ø128 [Ø5.04] (C2)	G4" (C3)	Ø11.5	M10	Ø240	Ø203	Ø250
	S32 : 2-1/2-12 UN-2B (C1)	Ø95 [Ø3.74] (C2)	G2-1/2" (C3)	[Ø0.45]		[Ø9.45]	[Ø7.99]	[Ø9.84]
16 FR/L 0270	S40 : 3-12 UN-2B (C1)	Ø110 [Ø4.33] (C2)	G3" (C3)					

¹⁾ = Weight including standard filter element and maintenance indicator

²⁾ = Servicing height for filter element replacement

Dimensions in mm [inch]

Spare parts list

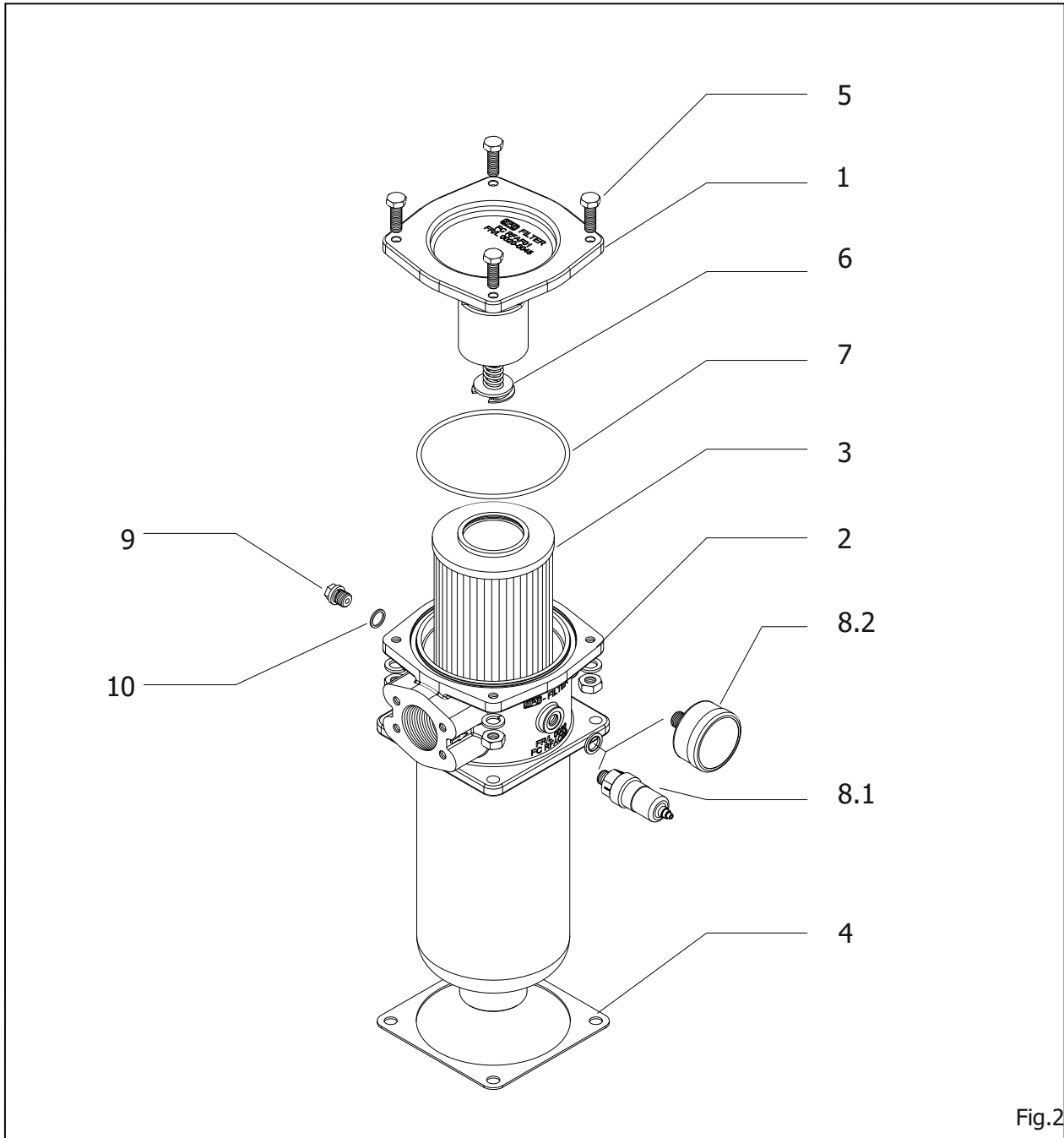

Fig.2

Spare Parts List

		Size FR/L Size FR/LN		0020 0160	0030 0250	0045	0060 0400	0095 0630	0120	0145 1000	0200	0270
Item #	Qty.	Description	Material									
1	1	Top Cover	Aluminium	-								
2	1	Filter Housing	Aluminium	-								
3	1	Filter Element	Various	As per "Ordering Code - Filter Element"								
4	1	Housing Gasket	Buna N/Viton	Sold as kit - "Ordering Code - Filter Seal Kit"								
5	4	Bolt + Nut + Washer	-	M12 x 1.5 - 45mm lg Hex. Screw + Nut + Washer								
6	1	Bypass Valve Assy.	Various	-								
7	2	Top Cover O-Ring	Buna N/Viton	Sold as kit - "Ordering Code - Filter Seal Kit"								
8.1	1	Electrical Indicator	Various	As per Section "Maintenance Indicator"								
8.2	1	Pressure Gauge	Various	As per Section "Maintenance Indicator"								
9	1	Air Vent Plug	Steel	Part No.AVP01								
10	1	Seal Ring for air vent	Copper	Sold as kit - "Ordering Code - Filter Seal Kit"								

xx - Cracking pressure (bar)

Installation

Before installation, conduct a visual check to ensure that the filter has not suffered any damage during shipping / handling.

Verify that the requested type matches with what stamped on the nameplate.

Check that the pressure rating of the filter is suitable for the system in which it is being installed.

During assembly of the filter the tightening torques (refer page 4), the flow direction (inlet on top and outlet below the bowl) and the required service height (A3 in fig.1) for removing the filter element (3) are to be considered.

Before the assembly, the hole pattern of the tank must be compared to the tank bore dimensions in fig.1. Check that the installation opening for assembling the filter in the tank cover is not too large so that unobjectionable sealing is guaranteed.

Remove the inlet & outlet plugs. Also remove the cable ties used for holding the gasket (4), if any.

Locate the filter housing (2) in the opening in the tank.

Make sure the optical part of the indicator is visible and/or the electricals connected appropriately. If the maintenance indicator is ignored the bypass valve, if available, will open when the pressure differential increases thereby bypassing the filter element and contaminated fluid will pass to the clean side of the filter outlet thereby compromising the filtration effectiveness.

Ensure that the gasket (4) is correctly located and screw the filter mounting bolts to specified torques (page 4), taking care to avoid any stress on the components.

Connect the inlet piping ensuring the filter is not subjected to any abnormal forces / transmission of vibrations. Tighten the inlet connection to the specified torques.

We recommend using a suitable safety relief valve in the system to ensure the user and equipment are protected against possible damage caused by pressure surges.

These filters must be installed in vertical position into the tank with the filter bowl downward.

It is recommended to lead drain pipes of a length of upto 500 mm in a bracket in order to avoid oscillations caused by the fluid flow in the tank.

It is to be ensured that in case of maintenance works, the filter housing and the drain pipe are pulled out together.

If used in inline applications ensure the bottom port is used for the outlet.

Connecting electrical indicator

Connect indicator using the three wired cable.

Verify electrical ratings on the indicator (11) name plate.

Connection settings:

Normally Open 1 (black) + 2 (brown)

Normally Closed 1 (black) + 3 (blue)

Switch-Over 1 (black) + 2 (brown) + 3 (blue)

Starting Operation

Switch on the service pump.

Monitor the static-up pressure on the servicing display of the return filter and return pipe, respectively.

If the static-up pressure before the return filter is more than 1 bar, check the volume flow of the pump and the dimensional layout of the return filter.

Maintenance

The filter element (4) is clogged and must be renewed or cleaned when the manometer reading has reached the marked value, the visual pointer extends from the maintenance indicator at operating temperature and/or the switching process on the electrical indicator is triggered.

Filter element service

Switch off the pump and depressurise system.

Unscrew the hexagonal screws (5) alternating them and remove the top cover (1) & top cover O-ring (7).

Pull out the filter element (3).

Check and, if necessary clean the filter housing (2).

Filter element of type H...XL, H...XP, H...XE, H...XC, AS..., P... and VS ... is to be replaced.

Filter element with G... media is cleanable. The effectiveness of cleaning depends on the type of dirt and the level of the differential pressure at the time of changing the filter element. If the differential pressure after the filter element's cleaning process exceeds more than 50% of the pre-service value the G...filter element also needs to be replaced.

Remove the safety packing from the new filter element before installing in the filter.

Replace filter element by slightly turning it back on its locator. Check gasket (4) and top cover O-ring (7), replace in case of damage or wear. For filters with bypass install bypass valve assembly (6) into top cover (1). Mount top cover (1) - with top cover o-ring (7) in place - onto filter housing (2) ensuring the filter element (3) is properly seated onto the spigot. Screw the hexagonal screws (5) alternating them and tighten to specified torque (page 4). Operate filter as described above.

Pressure Directives

Return Line Filters for hydraulic application are pressure holding equipment according to Article 2 Section 5 of the Pressure Equipment Directive 2014/68/EU. However, on the basis of the exception in Article 1, Section 2(f) of the PED the pressure line filters are exempt from the PED if they are not classified higher than category I (Guideline A-19) & do not receive any CE mark.

Disposal / Environmental Protection

Careless disposal of the filter, filter element and the residual fluid contained therein can cause environmental pollution.

Dispose the filter / filter element in accordance with provisions applicable in the country of use.

Fluid residues are to be disposed according to the respective safety data sheets valid for the specific hydraulic fluids.

Performance Curves (Flow rate Vs Pressure Drop) - for complete filters

Oil Viscosity : 30 mm²/s [142 SUS]
 Specific gravity < 0.9 kg/dm³
 Recommended initial Pressure Drop (ΔP) for assembly = 0.8 bar [11.6 psid]

